

INSTALLATION

!CAUTION!

• This product is not intended for life or safety applications

Severe injury or death can result from electrical shock during contact with high voltage conductors or related equipment. Disconnect and lock-out all power sources during installation. Applications shown are suggested means of installing relays, but it is the responsibility of the installer to ensure that the installation is in compliance with all national and local codes. Installation should be attempted only by individuals familiar with codes, standards, and proper safety procedures for high-voltage installations. Do not rely on status indications of device exclusively to determine if power is present in conductor.

Ensure load and coil source are shut off and locked out before any installation

- Using the threaded nipple connect the relay housing to the desired enclosure through a knock out.
- Secure with the conduit nut provided.
- Connect Coil:
 - Choose the coil common lead (White with Yellow Stripe) and connect it to the (-) source termination point.
 - Choose either the low (24VAC/DC White w/blue stripe) or high (120VAC White w/black stripe) voltage lead, whichever fits your application. Connect it to the (+) source termination point.*

NOTE: When connecting the control side of this device (#18 wires) to power line circuits, current limiting is to be provided of 7 amps max.

4. Connect Relay Contacts:

OUTPUT #1

- Choose the relay common lead (Yellow Solid) and connect to switched load.
- Choose the relay N.O. (Orange Solid) and/or* N.C. (Blue Solid) lead and connect to switched load.

OUTPUT #2

- Choose the relay common lead (Violet Solid) and connect to switched load.
- Choose the relay N.O. (Brown Solid) and/or* N.C. (Grey Solid) lead and connect to switched load.

5. Secure your enclosure and reconnect power.

*Wires which are not terminated must be isolated or insulated, e.g. wire nut.

WIRING EXAMPLES

Nipple mount directly to a panel

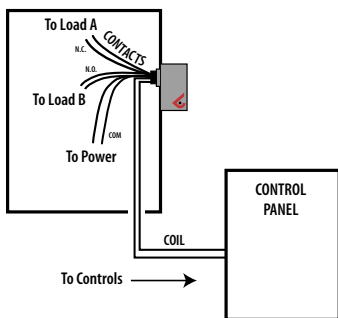

Nipple mount to any 2x or 4x electrical box

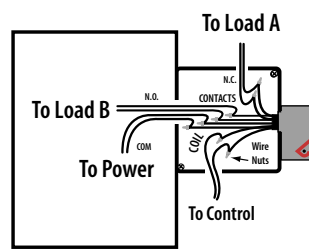

*Any unused wires must be isolated, e.g. wire nut.

Installation Instructions

Victory 320

20A DPDT Enclosed Relay

VERIS INDUSTRIES



PORTLAND, OREGON USA
 (503) 598-4564 FAX (503) 598-4664
 1-800-354-8556

http://www.veris.com email:sales@veris.com

WIRE COLORS

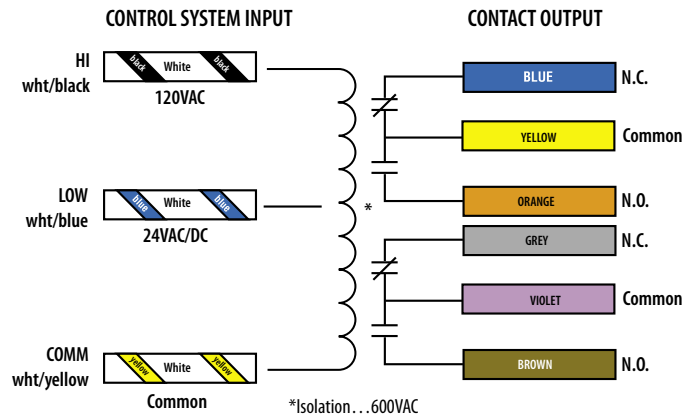

HOUSING APPEARANCE

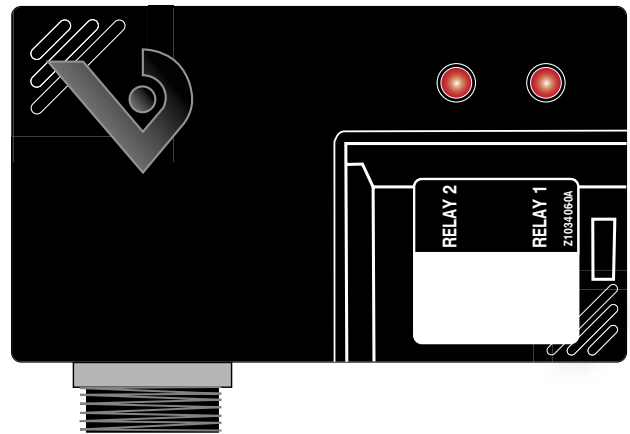

SPECIFICATIONS

General

Operating Temp..... -40° to 40°C
Operating Humidity 0-95% non condensing
Expected Relay Life 10 million cycles min. mechanical
Relay Status..... LED ON = energized
Dimensions..... 4.0"(L) x 2.04"(W) x 2.50"(H) 3/4" NPT nipple

TYPICAL COIL PERFORMANCE

Coil Voltage: 24VAC/DC, 120VAC

Voltage	Coil Current	
	AC	DC
24V.....	85mA	64mA
120V.....	84mA	—

CONTACT RATINGS

Resistive..... 20A(r)@277VAC, 28VDC
Motor..... 120VAC, 1HP
277VAC, 2HP
Ballast..... 20A@277V N.O., 10A@277V N.C.
Tungsten..... 10A@120 N.O., 2A@120N.C.
Pilot Duty.... A300