

V300



V300

10A DPDT Enclosed Relay

Installer's Specifications

Operating Temperature	-34°C to 60°C (-29° to 140°F)
Operating Humidity	10-90% non condensing
Expected Relay Life	Electrical (at rated current): 100,000 cycles Mechanical (unpowered): 10,000,000 cycles
Relay Status	LED ON=energized
Wire Specifications:	
Lead Length	14" (356mm) min.
Gauge	UL1015; Coil: 18AWG; Contacts: 16AWG
Insulation Class	600VAC RMS
Agency Approvals	UL508 enclosed device listing



DANGER

HAZARD OF ELECTRIC SHOCK, EXPLOSION, OR ARC FLASH

- Follow safe electrical work practices. See NFPA 70E in the USA, or applicable local codes.
- This equipment must only be installed and serviced by qualified electrical personnel.
- Read, understand and follow the instructions before installing this product.
- Turn off all power supplying equipment before working on or inside the equipment.
- Use a properly rated voltage sensing device to confirm power is off.
DO NOT DEPEND ON THIS PRODUCT FOR VOLTAGE INDICATION
- Only install this product on insulated conductors.

Failure to follow these instructions will result in death or serious injury.

NOTICE

- This product is not intended for life or safety applications.
- Do not install this product in hazardous or classified locations.
- The installer is responsible for conformance to all applicable codes.
- Mount this product inside a suitable fire and electrical enclosure.

QUICK INSTALL

Disconnect and lock out all power sources before beginning the installation.

1. Using the threaded nipple, connect the V300 to the desired enclosure through a knock out.
2. Secure with the conduit nut provided.
3. Connect Coil:
 - Choose the coil common lead (white with yellow stripe) and connect it to the (-) source termination point.
 - Choose either the low voltage (20-30VAC/DC, white with blue stripe) or high voltage (120VAC, white with black stripe) lead, depending on the application requirements, and connect it to the (+) source termination point.*
4. Connect Relay Contacts:
 - Choose the relay common wire (yellow) and connect to switched load.
 - Choose the relay N.O. (orange) and/or* N.C. (blue) lead and connect to switched load.
5. Secure your enclosure and reconnect power.

* Wires that are not terminated must be isolated or insulated, i.e. wire nut.

DIMENSIONS

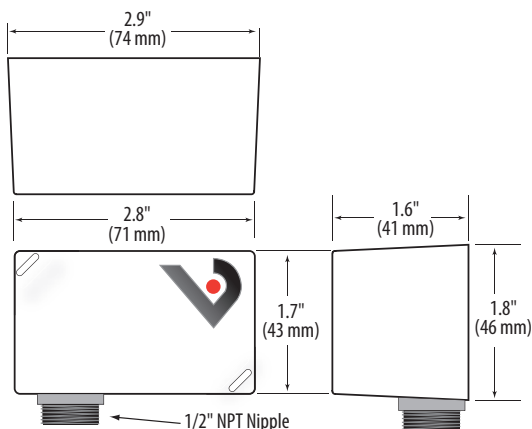

WIRING COLOR CODES

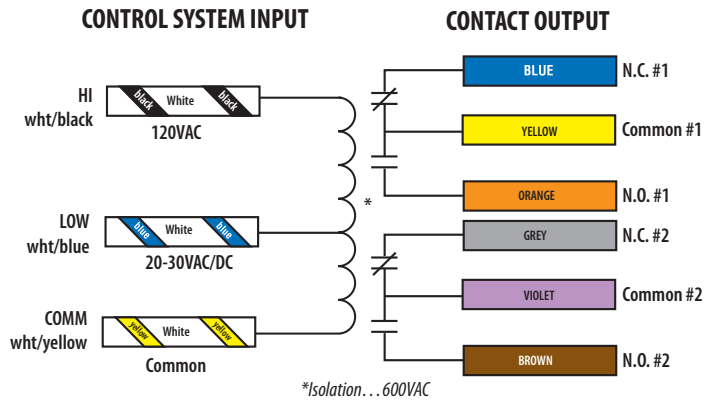

WIRING EXAMPLE

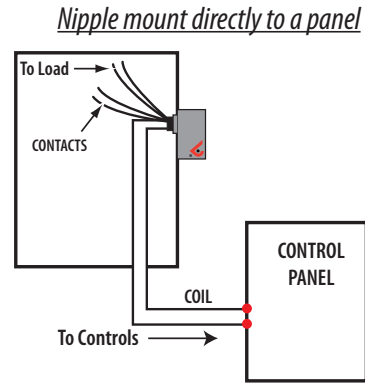

CONTACT AND COIL SPECIFICATIONS

Nipple mount to any 2x or 4x electrical box

TYPICAL COIL PERFORMANCE		
Pull in Voltage	AC	DC
20-30V.....	18	20
120V.....	104	
Drop Out Voltage	AC	DC
20-30V.....	4	5
120V.....	26	
Voltage	Coil	Current
	AC	DC
24V.....	43mA	25mA
30V.....	54mA	31mA
120V.....	29mA	-

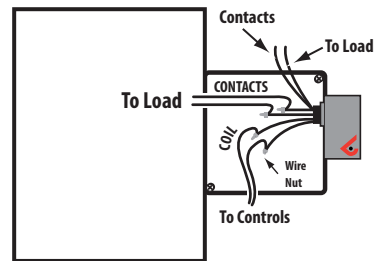

CONTACT RATINGS*	
Resistive.....	10A@277VAC, 30VDC
Motor.....	120VAC, 1/8HP
*Contact ratings are for single pole operation. When operating both poles simultaneously, the total load cannot exceed the ratings above.	