

TWS SERIES



TWS SERIES

LCD Wall Mount with Analog Setpoints

Installer's Specifications

Power Supply*	15 to 30VDC/24VAC, 100mA max.
Outputs, Analog	Switch Selectable 4-20mA or 0-10V/0-5VDC (switch affects both outputs)
Stability	±1% @ 20°C (68°F) annually, for two years
Temperature Coefficient	± 0.1%RH/°C above or below 25°C (typical)
Operating Temperature Range	10° to 35°C (50° to 95°F)
Temperature Accuracy	±0.5°C (±0.9°F)
Scaling	10° to 35°C (50° to 95°F) or 0° to 50°C (32° to 122°F) menu selectable
Calibration Offset	Adjustable ±9.9° in 0.1° increments
Setpoint Range	Minimum to Full Scale in 1° increments

* One side of transformer secondary is connected to signal common, so an isolation transformer or dedicated power supply may be required.

To maintain CE compliance the connected power supply must have a CE mark supporting LV + CE directives.

RTD/Thermistors in wall packages are not compensated for internal heating of product.

NOTICE

- This product is not intended for life or safety applications.
- Do not install this product in hazardous or classified locations.
- Read and understand the instructions before installing this product.
- Turn off all power supplying equipment before working on it.
- The installer is responsible for conformance to all applicable codes.

PRODUCT IDENTIFICATION

Setpoint	Cal Certificate	Option
TWS <input type="checkbox"/> A	<input type="checkbox"/>	<input type="checkbox"/>
= Analog	0 = None	Blank = None
<input type="checkbox"/> S	1 = 1 point Cal Validation	B = 100R Platinum, RTD
	2 = 2 point Cal Validation	C = 1k Platinum, RTD
		D = 10k T2, Thermistor
		E = 2.2k, Thermistor
		F = 3k, Thermistor
		G = 10k CPC, Thermistor
		H = 10k T3, Thermistor
		J = 10k Dale, Thermistor
		K = 10k w/11k w/Shunt, Thermistor
		M = 20k NTC, Thermistor
		N = 1800 ohm TAC, Thermistor
		Q = 1uA/C, Linitemp
		R = 10k US, Thermistor
		S = 10k 3A 221, Thermistor
		T = 100k, Thermistor

QUICK INSTALL

1. Select a mounting location away from ventilation sources. The sensor should be mounted on a vertical wall, about 4 1/2 feet above the floor.
2. Affix the backplate to the wall.
3. Wire the device. Refer to wiring diagram.
4. Install Cover.

DIMENSIONS

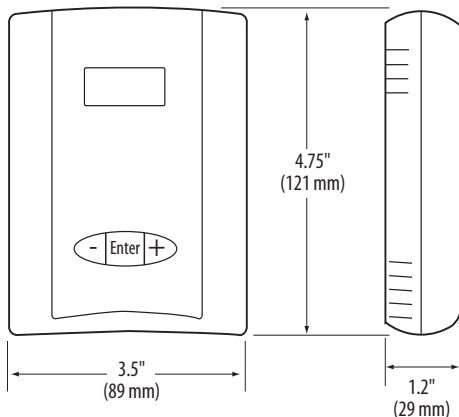

INSTALLATION

1. Remove the cover by pressing the tab at the top of the sensor while pulling outward from the top of the cover.



2. Remove the backplate by unfastening the sensor from the bottom of the backplate and pivoting the sensor outward.



3. Punch out openings in the backplate.

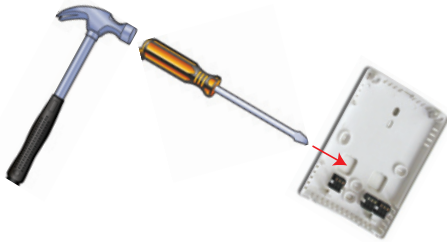

4. Position the sensor vertically on the wall, 4 1/2 feet above the floor.



correct



incorrect

5. Mount the backplate onto the wall using the screws provided.

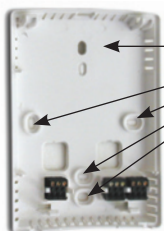

Five screwholes available; use a minimum of two for secure mounting.

6. Wire the backplate.

Output (3-Wire, 0-10V, 4-20mA)

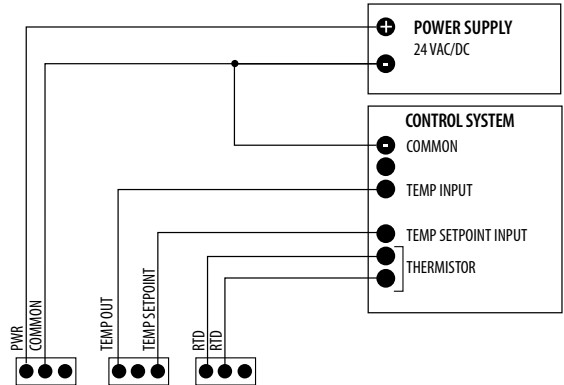

7. Install and configure the sensor.

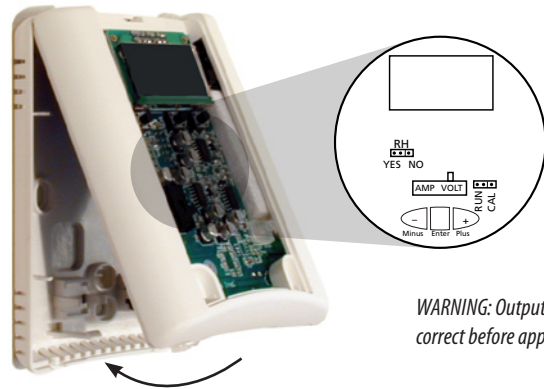

WARNING: Output select must be correct before applying power.

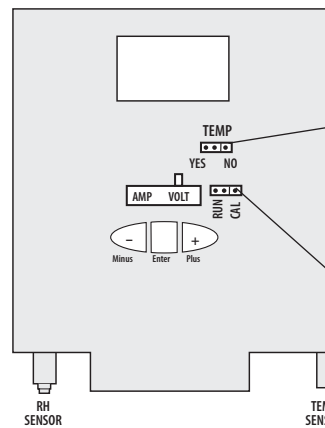

TEMP YES/NO JUMPER:
 YES - allows user to change setpoint (in thermostat mode)
 NO - user can NOT change setpoint (in thermostat mode)

RUN/CAL JUMPER:
 CAL Mode - allows full access to all features.
 RUN Mode - allows access to setpoint ONLY.

8. Install the cover and snap into place.



MENU

TWS CALIBRATION INSTRUCTIONS

Temperature calibration allows for calibration offset of $\pm 9.9^{\circ}\text{F}$ ($\pm 5^{\circ}\text{C}$) at user discretion. Temperature can be field calibrated by moving the RUN/CAL jumper to CAL position.

NORMAL MODE

6	8	.	5			°	F



SETPOINT MODE

(Enter by any keypress when RUN/CAL jumper is in RUN position)



S	E	T	P	O	I	N	T
		7	0				F

press ± to change; press * to select
(setpoint in °C if Celsius units are selected)



CONFIG/CAL MODE

(Enter by any keypress when RUN/CAL jumper is in CAL position)



U	N	I	T	S			
*	°	F				°	C

press ± to change; press * to select



S	E	T	P	O	I	N	T
		7	0				F

press ± to change; press * to select
(setpoint in °C if Celsius units are selected)



C	A	L		T			
+	0	.	0				F

press ± to change; press * to select
(cal in °C if Celsius units are selected)



Output scaling
(does not affect LCD display)

T	E	M	P		S	E	T
+	5	0			+	9	5

press ± to change; press * to select
(choices are 50-95 °F/10-35 °C or 32-122 °F/0-50 °C)



Only for switch in
Volts position

	O	U	T	P	U	T	
	0	-	1	0	V		

press ± to change; press * to select