

PW2 SERIES



 available

PW2 SERIES

Wet Media Differential Pressure Transducer

Installer's Specifications

Media Compatibility	17-4 PH stainless steel
Input Power	12 to 24VDC, 29mA max.; loop powered
Output	2-wire transmitter; 4-20mA (clipped and capped)
Pressure Ranges:	
0-50 psi (0-3.45 bar)	5/10/25/50 psid (0-0.34/0.69/1.72/3.45 bar)
0-100 psi (0-6.89 bar)	10/20/50/100 psid (0-0.69/1.38/3.45/6.89 bar)
0-250 (0-17.24 bar)	25/50/125/250 psid (0-1.72/3.45/8.62/17.24 bar)
Proof Pressure	2x max. F.S. range
Burst Pressure	5x max. F.S. range
Accuracy at 25°C*	Ranges A, B, C: ±1% F.S.** Range D: ±2% F.S.**
Surge Damping	Electronic; 5-second averaging
Temperature Compensated Range	0° to 50°C (32° to 122°F); TC Zero <1.5% of product F.S. per sensor; TC Span <1.5% of product F.S. per sensor
Sensor Operating Range	-20° to 85°C (-4° to 185°F)
Long Term Stability	±0.25% per year
Zero Adjust	Pushbutton auto-zero
Operating Environment	-10° to 55°C (14° to 131°F); 10-90% RH noncondensing
Fittings	1/8" NPT female, stainless steel 17-4 PH
Physical	White powder-coated aluminum

To conform to EMC Standards, use shielded cabling. Technical information is available from the factory on request or on our website (www.veris.com/ce)

* Accuracy combines linearity, hysteresis, and repeatability.

** F.S. is defined as full span of selected range in bidirectional mode.

The PW2 Series sensor is designed to accept high differential pressure. Install the sensor on a duct or pipe across a pump, filter, heat exchanger, compressor, or other non-corrosive wet media. The dual sensor design eliminates the need for a bypass valve, and the bi-directional capability reduces installation errors. A pushbutton allows easy zero adjustment.

QUICK INSTALL

1. Mount sensor on a duct or pipe, across the pump, filter, or other pressure differential.
2. Wire as shown (see page 2).
3. Configure the jumpers (see page 2).

NOTICE

- This product is not intended for life or safety applications.
- Do not install this product in hazardous or classified locations.
- Read and understand the instructions before installing this product.
- Turn off all power supplying equipment before working on it.
- The installer is responsible for conformance to all applicable codes.

PRODUCT IDENTIFICATION

Local Display	NIST	Operational Range	US or EU
PW2 <input type="checkbox"/>	<input type="checkbox"/>	<input type="checkbox"/> *	<input type="checkbox"/>
L = LCD Display X = No Display	N = NIST X = None	03 = 0-50 psig 04 = 0-100 psig 05 = 0-250 psig	S = Standard C = CE

*** IMPORTANT!**

Select operational range according to maximum gauge pressure, NOT differential pressure.
Example: High gauge pressure=90 psig, Select 100 psig model (04).

DIMENSIONS

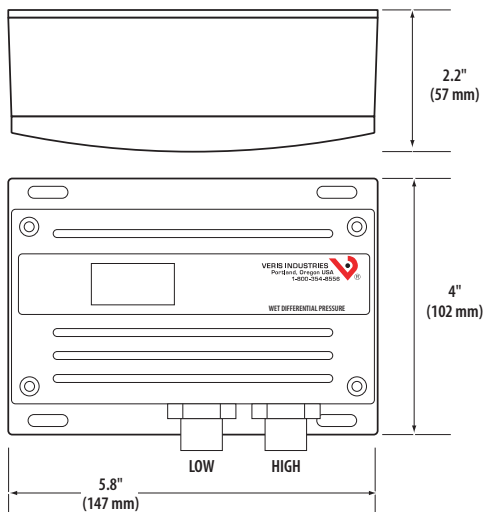

WIRING

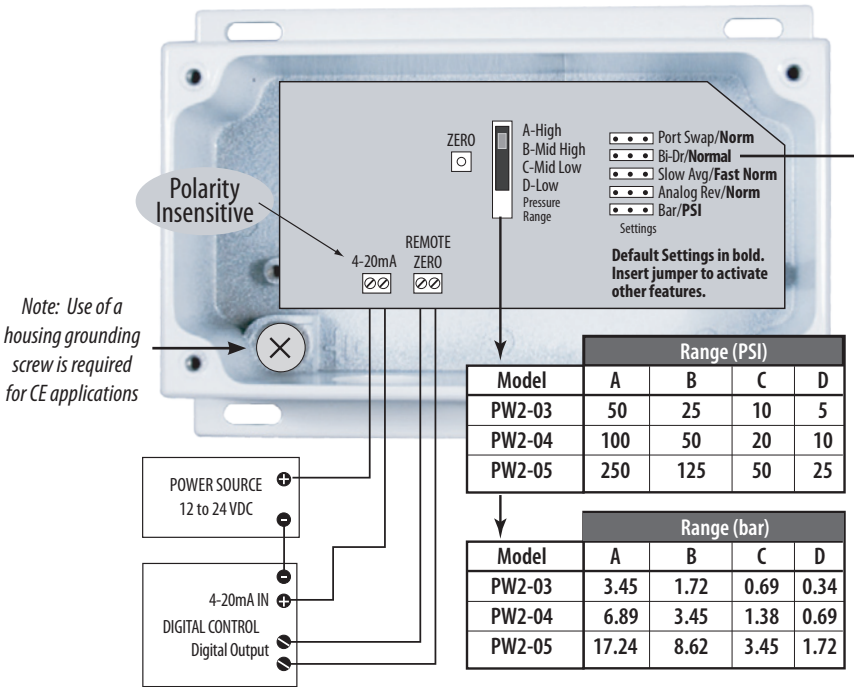

*Output is mA only.
Example: PW2-04*

Bidirectional Operation			
Input Conditions		Result	Outputs Read
HI PORT	LO PORT	DP	4-20mA
100 psi	0 psi	+100 psi	20mA
100 psi	50 psi	+50 psi	16mA
50 psi	50 psi	0 psi	12mA
50 psi	100 psi	-50 psi	8mA
0 psi	100 psi	-100 psi	4mA

Model	Range (PSI)			
	A	B	C	D
PW2-03	50	25	10	5
PW2-04	100	50	20	10
PW2-05	250	125	50	25

Model	Range (bar)			
	A	B	C	D
PW2-03	3.45	1.72	0.69	0.34
PW2-04	6.89	3.45	1.38	0.69
PW2-05	17.24	8.62	3.45	1.72

Optional: Connect Zero terminals to digital output (contact closure) of control system.

Caution: Zero input is for dry-contact only. Do not apply voltage to the Zero terminals.

Range: Use the Range switch to select F.S. differential pressure.

CONFIGURATION

Jumper	Notes
Port Swap/Norm	Reverses polarity of the pressure ports (i.e. makes the LO port operate as the HI port and vice versa); used when the sensor is incorrectly plumbed.
Bi-Dr/Normal	Normal: 0 to F.S. pressure Bidirectional: -F.S. pressure to +F.S. pressure; output reads ½ when pressure is zero.
Slow Avg/Fast Norm	Slow mode provides 5 second averaging for surge damping.
Analog Rev/Norm	Normal: output increases as pressure increases; Reverse: output is maximum when pressure differential is zero and decreases as pressure increases.
Bar/PSI	Select output units.

OPERATION

Auto-Zero: Press and hold the Zero button for 2 seconds or provide contact closure on the auxiliary 'Remote Zero' terminal to reset the output to zero pressure. To protect the device from accidental zeroing, this feature is only enabled when the detected pressure is within 5% of factory calibration.