

# H40 SERIES



# Hawkeye™ 40NE8A/40ME8X

## Fractional Motor Status Sensor/ Command Relay

### Installer's Specifications

Operating Temperature Range	-15°C to 50°C (5° to 122°F)
Operating Humidity Range	0-95% non-condensing
Frequency Range	50-60 Hz
Wire to Relay Contacts	Use 12 AWG (3.3 mm <sup>2</sup> ) or larger wire
Low Voltage Terminal Block Tightening Torque	3.5 lb-in
<b>Relay:</b>	
Type	H40NE8A: SPST N.O.; H40ME8X: SPST N.O. or N.C.
Contact Ratings	H40NE8A: 16A@120/250VAC, 12A@277VAC, 1HP@120VAC, 8A@28VDC H40ME8X: SPDT 16A@120/277VAC, 1HP@120VAC, 2HP@277VAC, 16A@28VDC
Coil Ratings	24VDC 45mA nom.; 24VAC 78mA nom.; Class 2*
<b>Current Sensor:</b>	
Sensor Supply Voltage	Induced
Status Output Rating	N.O. 1.0 A at 30 VAC/DC; Class 2
Amperage Rating	0.25 to 16 A continuous
Trip Point	Adjustable

\* In addition, coil input from other sources may be used as detailed in NEC 2008, Article 725.121.

## ⚠ DANGER ⚡

### HAZARD OF ELECTRIC SHOCK, EXPLOSION, OR ARC FLASH

- Follow safe electrical work practices. See NFPA 70E in the USA, or applicable local codes.
- This equipment must only be installed and serviced by qualified electrical personnel.
- Read, understand and follow the instructions before installing this product.
- Turn off all power supplying equipment before working on or inside the equipment.
- Use a properly rated voltage sensing device to confirm power is off.  
**DO NOT DEPEND ON THIS PRODUCT FOR VOLTAGE INDICATION**
- Only install this product using insulated conductors.

**Failure to follow these instructions will result in death or serious injury.**

## NOTICE

- This product is not intended for life or safety applications.
- Do not install this product in hazardous or classified locations.
- The installer is responsible for conformance to all applicable codes.

### QUICK INSTALL

1. Disconnect power sources prior to installation.
2. Mount to an electrical enclosure using the 1/2" threaded nipple.
3. Connect line voltage wires.
4. Open the lid to reveal the low voltage section and connect relay coil and status terminals to control wiring.
5. Apply power and adjust current sensor to desired trip point.
6. Close lid to low voltage section.

### DIMENSIONS

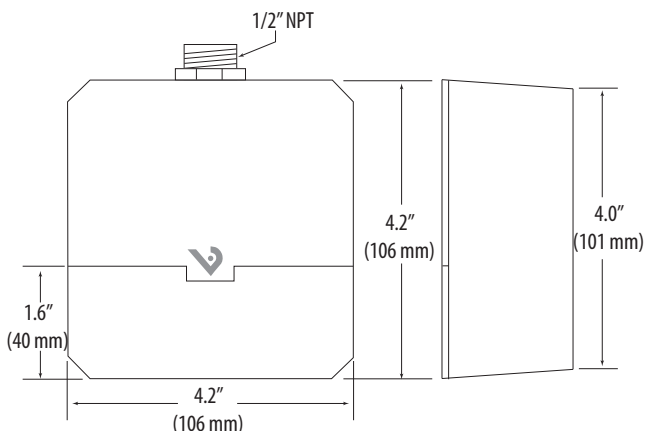

### RELAY CONNECTION

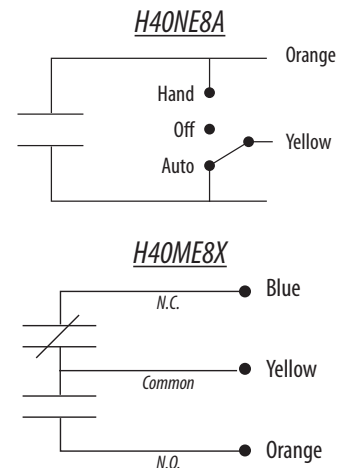

**OPERATION**

H40 devices combine a switching relay, a current status sensor, and a Hand-Off-Auto (HOA) switch (H40NE8A only) into a single housing. The low voltage and line voltage wires are electrically separated from each other. A hinged lid on the low voltage side allows easy relay connection (both devices) and trip point adjustment, while the high voltage side is closed for added safety.

The H40 is connected in series between the power source and the motor device, and the relay and HOA switch control the on/off functioning of the motor. The current sensor trip point is adjustable on the from 0.25 to 16A, with a maximum load of 16A for both devices.

**WIRING EXAMPLE**

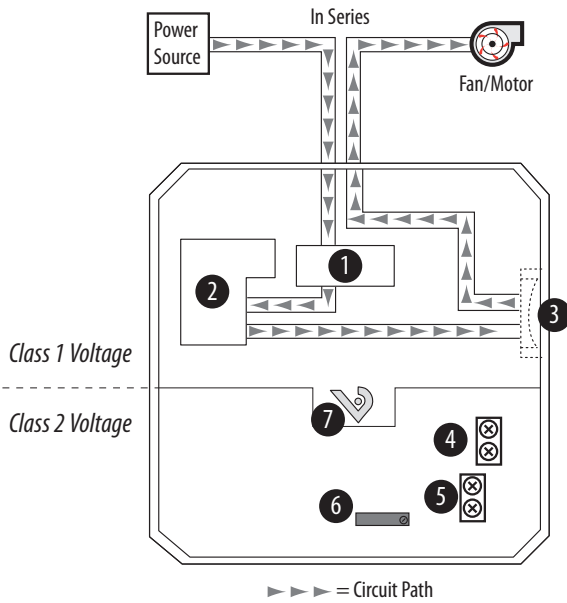

1. Current Sensor: In-series with motor
2. Relay: Enables actuation of circuit by a control system
3. HOA Switch: Provides local control of the motor (H40NE8A only)
  - HAND - When the switch is in this position, the motor is always on.
  - OFF - When the switch is in this position, the motor is always off.
  - AUTO - When the switch is in this position, the control system commands the motor.
4. Relay Coil terminal block: Wire output signal from control panel to actuate the relay. 24 VAC/DC, 45 mA nominal.
5. Current Sensor Status terminal block
6. Setpoint Adjustment Screw: Adjust the trip point from 0.25 to 16 A
7. Status LED:
  - Left side of V - Green = Output Contact Closed; Red = Output Contact Open
  - Right side of V - Green = Coil is energized

Only the terminal blocks and the setpoint adjustment screw are accessible through the hinged lid. Other components are in the sealed high voltage compartment.

**INSTALLATION**

Prior to installation, disconnect and lock out all power sources.

1. Insert 1/2" nipple into a knockout hole on a standard junction box. Use the nut (included) to ensure a secure fit.
2. Use a wire nut to connect the line side wires on the H40. The H40NE8A has two high voltage wires (orange = normally open, yellow = common), while the H40ME8X has three (blue = normally closed, orange = normally open, yellow = common).

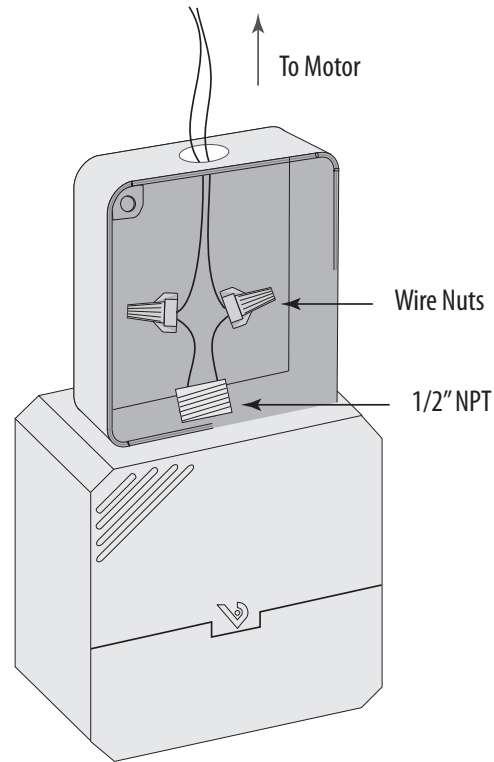

3. Use a flat screwdriver to open the low voltage compartment. Connect relay coil and status terminals to control wiring.

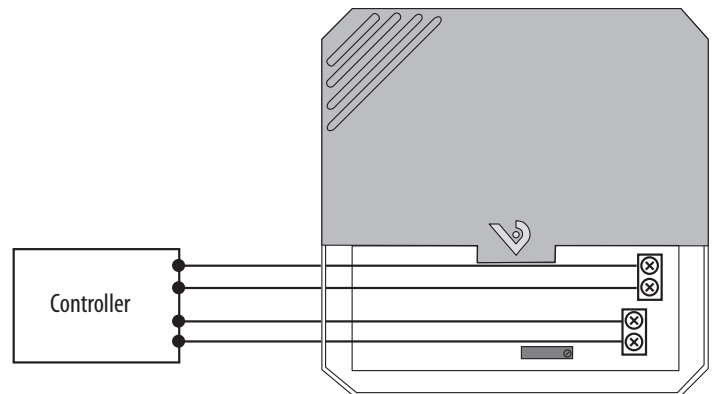

4. Reconnect power.
5. Use a small screwdriver to adjust the setpoint screw to the desired trip point (between 0.25 and 16 A).
6. Close low voltage lid.

## **CALIBRATION (H40NE8A ONLY)**

Testing the status output of this sensor with a digital ohmmeter may yield inaccurate, but relative, readings of switching (e.g. 6 M $\Omega$ ). Use an analog volt-ohm meter for reading similar to loop values. Calibrate the sensor with load at normal operating conditions.

### 1. For under-current status indication: (Belt loss, fan & pump status)

- Turn the set point screw clockwise until the status closed LED goes out and the status open LED comes on.
- Turn the set point screw counter-clockwise until the status open LED goes out and the status closed LED comes on.
- Turn the set point screw 1/2 turn counter-clockwise.
- The sensor is now calibrated to provide indication of current flow below normal full load amps.

#### Output Status:

Normal: Output closed

Alarm: Output open

### 2. For over-current status indication: (Locked rotor)

- Turn the set point screw counter-clockwise until the status open LED goes out and the status closed LED comes on.
- Turn the set point screw clockwise until the status closed LED goes out and the status open LED comes on.
- Turn the set point screw clockwise 1/2 turn
- The sensor is now calibrated to provide indication of current flows above normal full load amps

#### Output Status:

Normal: Output open

Alarm: Output closed