

Communicating Humidistat Series

BACnet, Echelon, & Wireless Models Available



VH7200A1000

DESCRIPTION

The VH7200 humidity controller family features a complete embedded humidity control solution with an intuitive backlit LCD display that walks the installer through the configuration steps, making the process extremely simple. Accurate relative humidity control is achieved via the product's unique PI time proportional control algorithm, which virtually eliminates humidity offset associated with traditional, differential-based humidity controllers.

All models contain a user-controlled binary input, which monitors an electrode humidifier canister service status or may be used as a general purpose service indicator. Models are available with more advanced features such as discharge humidity, proportional high limit, and indoor humidity setpoint reset based upon outdoor air temperature.

APPLICATIONS

- Humidifier
- Dehumidifier/air exchanger
- Humidity high limit sensor
- Outdoor air temperature sensor
- Airflow switch

FEATURES

- PI time proportioning algorithm...increased comfort, accuracy, and energy savings
- Binary input...adds functionality
- Unique local configuration utility...minimizes parameter tampering
- Lockable keypad...tamper proof, no need for thermostat guards
- EEPROM memory...no loss of program
- Optional remote humidity sensors...increased flexibility and functionality
- Embedded humidification sequence (0-10VDC output) and dehumidification sequence (dry contact)...simplifies installation and reduces costs
- Internal RH sensor embedded...eliminates components
- Proportional high limit override (VH7270 models only)...prevents costly damage due to over-humidification
- Humidity setpoint reset based on outdoor temperature (VH7270 models only)... saves energy and prevents window condensation in colder climates
- Sensor failure protection...prevents water damage

SPECIFICATIONS



Humidistat Power Requirements	19-30VAC; 50 or 60 Hz; 2 VA (RC & C) Class 2
Operating Conditions	0° to 50°C (32° to 122°F); 0 to 95% RH non-condensing
Storage Conditions	-30° to 50°C (-22° to 122°F); 0 to 95% RH non-condensing
Resolution	Temp: ±0.1°C (±0.2°F); Humidity: ±0.1%
Control Accuracy	Humidity: ±3% RH from 20 to 70% RH at 21°C (70°F)
Humidification Setpoint Range	10 to 90% RH
Dehumidification Setpoint Range	15 to 95% RH
Outdoor Air Temperature Range	-40° to 50°C (-40° to 122°F)
Binary Inputs	Relay dry contact only across Scom and DI1 terminals
Contact Output Rating	Each relay output: 30VAC, 1A max.; 30VAC, 3A in-rush
Analog Output Rating	0-10VDC into 2kΩ resistance min.
Wire Gauge	18 gauge maximum, 22 gauge recommended
Dimensions	4.94" x 3.38" x 1.13"
Approximate Shipping Weight	0.75 lb (0.34 kg)

UL: 873 (US) and CSA C22.2 No. 24 (Canada), File E27734 with CCN, XAPX (US) and XAPX7 (Canada)
 FCC: Compliant to CFR 47, Part 15, Subpart B, Class A (US)
 Industry Canada: ICES-003 (Canada)
 CE: EMC Directive 89/336/EEC (European Union)
 C-Tick: AS/NZS CISPR 22 Compliant (Australia / New Zealand); Supplier Code Number N10696

SETPOINT DEVICES

APPLICATION/WIRING EXAMPLE

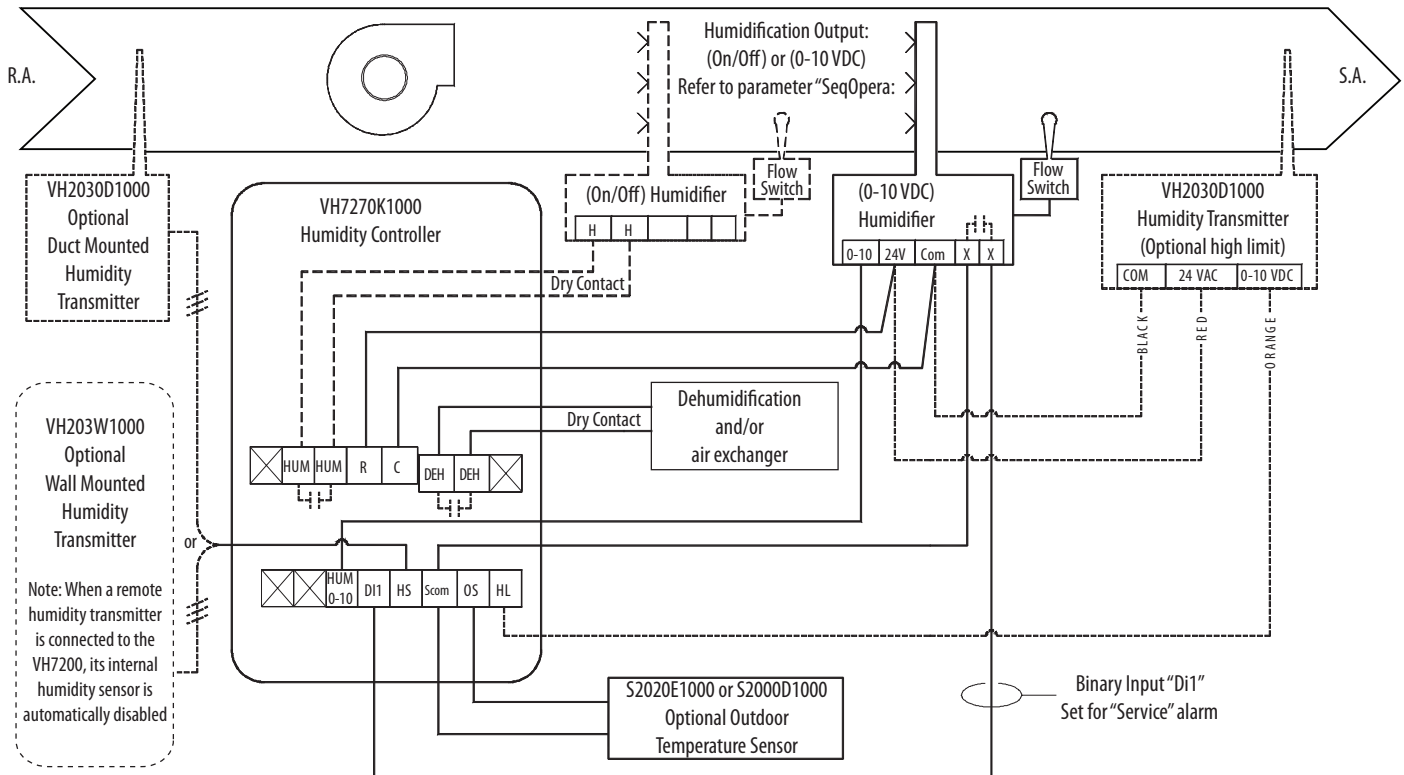

DIMENSIONAL DRAWING

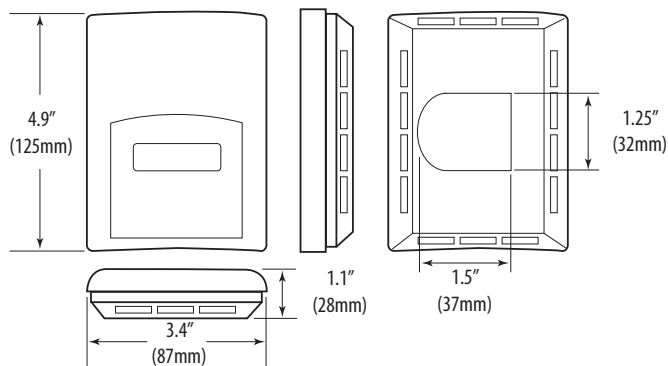

ORDERING INFORMATION



MANUF. PART #	ORDERING #	DESCRIPTION	COMM.
VH7200A1000	U007-0001		Stand alone
VH7200A1000B	U007-0002	On/Off Hum.; On/Off Dehum.; Outdoor Reset	BACnet (MS/TP)
VH7200A1000W	U007-0004		Wireless (Zigbee)
VH7270F1000	U007-0005		Stand alone
VH7270F1000B	U007-0006	0-10V Hum.; On/Off Dehum.; Prop HL; Outdoor Reset	BACnet (MS/TP)
VH7270F1000E	U007-0007		Echelon
VH7270F1000W	U007-0008		Wireless (Zigbee)
VH7270K1000	U007-0009		Stand alone
VH7270K1000B	U007-0010	0-10V Hum.; On/Off Hum.; On/Off Dehum.; Prop HL; Outdoor Reset	BACnet (MS/TP)
VH7270K1000E	U007-0011		Echelon
VH7270K1000W	U007-0012		Wireless (Zigbee)